



B&T SPC9/10/40/45 HA

WEAPON FAMILY

## OPERATOR MANUAL



B&T AG  
3608 Thun • Switzerland  
Fon +41 33 334 67 00  
info@bt-ag.ch  
www.bt-ag.ch

TM-SPC9\_10\_40\_45-HA-00-EN

## Table of content

1. General rules .....	5
1.1 Safety rules .....	5
1.2 Maintenance rules .....	5
2. Technical Specifications .....	6
2.1 Overview - SPC9 .....	6
2.2 General description .....	6
2.3 General Technical data .....	7
2.3.1 Technical data - SPC9 HA.....	8
2.3.2 Technical data - SPC10 G HA .....	8
2.3.3 Technical data - SPC40 G HA .....	9
2.3.4 Technical data - SPC45 HA.....	9
2.4 Variant overview .....	10
3. Nomenclature.....	12
3.1 Weapon complete.....	12
3.2 Weapon disassembled.....	12
4. Handling and operating procedures .....	13
4.1 Clearing weapon .....	13
4.2 Operating fire selector .....	13
4.3 Magazine catch .....	14
4.3.1 Operating magazine catch.....	14
4.3.2 Magazine catch standard magazine.....	14
4.3.3 Magazine catch Glock magazine .....	14
4.3.4 Magazine catch SIG magazine.....	14
4.4 Stock / Adapter .....	15
4.4.1 Retracting sliding stock.....	15
4.4.2 Extracting sliding stock .....	15
4.4.3 Retracting telescopic stock.....	16
4.4.4 Extracting telescopic stock .....	16
4.5 Pistol grip storage compartment.....	17
4.5.1 Open the pistolgripcover .....	17
4.5.2 Close the pistolgripcover.....	17
4.6 Iron sights .....	18
4.6.1 Engaging iron sights.....	18
4.6.2 Adjustments.....	18
4.7 Disassembly & Assembly Charging Handle .....	19
4.7.1 Disassembly Charging Handle.....	19
4.7.2 Assembly Charging handle .....	20
4.8 Bolt catch.....	21
4.8.1 Holding bolt in open position .....	21
4.8.2 Closing Bolt .....	21

4.9	Loading and unloading weapon .....	22
4.9.1	Loading weapon.....	22
4.9.2	Unloading weapon during firing sessions.....	22
4.9.3	Unloading weapon for storage.....	23
4.10	Firing the SPC9 .....	23
5.	Maintenance procedures .....	24
5.1	Disassembly.....	24
5.1.1	Disassembly of the weapon.....	24
5.1.2	Disassembly of the upper receiver.....	26
5.2	Cleaning and inspections.....	27
5.3	Reassembly.....	27
5.3.1	Reassembly of the weapon.....	27
5.3.2	Assembly of the upper Receiver .....	29
5.4	Functional check .....	31
5.5	Troubleshooting table .....	32
6.	Accessories.....	33
6.1	Stocks / Adapters.....	33
6.2	Magazines.....	34
6.3	Flashhider .....	35
6.4	Silencer .....	36
6.5	Lights .....	37
6.6	Sights.....	37
6.7	Grips .....	38
6.8	Slide cover .....	38
6.9	Brasscatcher .....	39
6.10	Maintenance .....	39
7.	Warranty statement .....	40

**Related documents:**

Parts catalogue .....	PC-SPC9-HA-EN
Parts catalogue .....	PC-SPC10 G-HA-EN
Parts catalogue .....	PC-SPC40 G-HA-EN
Parts catalogue .....	PC-SPC45-HA-EN

**ADVICE!**

This operator manual covers the entire SPC9/10/40 and 45 weapon family. On the Pictures show normally the Standard Version. Where necessary the operating steps are shown separately for the different variants

Due to continuous efforts to improve the weapon, it is possible that certain descriptions in this manual may differ from the actual weapon.

**Abbreviations**

POA:	Point of Aim
POI:	Point of Impact
MPI:	Mean Point of Impact
Left / right side:	Defined looking in firing direction.

## 1. General rules

READ MANUAL BEFORE USE.

### 1.1 Safety rules

1. Consider every weapon loaded until checked personally by the individual operator.
2. Always keep fingers off the trigger and outside the trigger guard until the sights are on target.
3. Always point the weapon in a safe direction.
4. Verify your target and the backstop.
5. Before firing always verify the serviceability and condition of both the weapon and ammunition.
6. Hearing and eye protection are mandatory..
7. Be sure to use NATO, SAAMI or CIP certified cartridges of correct caliber only.

#### SAFETY ADVICE!



Defects that can be traced back to the use of non NATO, SAAMI or CIP ammunition (especially reloaded cartridges) are not covered by the guarantee!

8. If a cartridge fails to ignite, keep the muzzle pointed in a safe direction and open the chamber only after a minimum of 30 seconds.
9. Live fire training should be carried out in open or well-ventilated areas to prevent excessive exposure to toxic gases.
10. Operate your weapon consciously and do not use excessive force.

### 1.2 Maintenance rules

1. The weapon is to be cleaned after each deployment or firing.
2. Any malfunctions are to be reported to the unit armorer or manufacturer.
3. The weapon is to be presented to the unit armorer for inspection after each mission or a minimum of once per year.

## 2. Technical Specifications

### 2.1 Overview - SPC9



### 2.2 General description

The SPC9/10/40/45 is a semi-automatic only pistol caliber carbine (PCC)

The working principle is recoil operation:

The recoil of a fired projectile is driving the bolt rearward. When traveling back, the bolt extracts and ejects the case of the fired cartridge, compresses the mainspring and cocks the internal hammer of the single action trigger group. At the very end of the bolt's travel, a hydraulic recoil buffer is stopping it gently and the compressed mainspring drives the bolt back against the barrel. While traveling forward, the bolt feeds a new cartridge out of the magazine into the chamber of the barrel. After completion of such a cycle, the weapon is loaded and armed.

The next shot is released by pulling the trigger.

The weapon has mechanical flip up sights, an additional reflex sight can be mounted on the accessory rail. The reflex sight can be included in the scope of delivery, depending on the version of the weapon.

Controls such as bolt catch, magazine catch, fire selector and charging handle are designed ambidextrous. The additional charging handle in the front can be mounted on either side of the weapon.

## 2.3 General Technical data

<b>Designation</b>	<b>SPC_HA</b>
Manufacturer	B&T AG - Switzerland
Operating system	Recoil operated, closed bolt blowback action
Sights	Flip-up iron sight with two aperture holes
Bore height	72 mm / 2.87 in
Rail height	38 mm / 1.49 in
Interfaces	2 NATO accessory rails, M-LOK(front left and right side)
Scope of delivery	Weapon with magazines, carrying sling, cleaning kit, case

Stock Options	Stock Length		Weight difference to Standard [kg]
	extracted [mm]	retracted [mm]	
Sliding stock (Stand.)	298	215	0
Telescopic Brace**	270	132	-0.85
Telescopic Stock**	253	121	-0.82
Pistol Adapter	190	190	-1.15

\*\* Extracted to the maximum, intermediate positions existent

The overall length is determined by adding the receiver length and the stock length.

Technical data are provided for information only and shall not serve as acceptance criteria.

### 2.3.1 Technical data - SPC9 HA

<b>Designation</b>	<b>SPC9 HA</b>
Product ID	BT-500001
Caliber	9x19 mm
Magazine capacity	15/30 round
Rifling	6 Grooves, Right hand twist

Typ		Standard	SD PDW	SD	PDW	SD US	PDW US	SPORT
Barrel Length	[mm]	230	115	115	167	115	150	408
Length Standard	[mm]	625	545	680	469	556	501	803
Length Receiver	[mm]	411	425	467	350	312	331	590
Width	[mm]	65						
Height*	[mm]	205						
Weight	[kg]	2.85	3.1	3.0	2.8	2.3	2.2	3.3

\* Without magazine, flip-up sights folded.

### 2.3.2 Technical data - SPC10 G HA

<b>Designation</b>	<b>SPC10 G HA</b>
Product ID	BT-500001-10-G
Caliber	10 mm AUTO
Magazine capacity	15 round
Rifling	6 Grooves, Right hand twist

Barrel Length	[mm]	230
Length Standard	[mm]	640
Length Receiver	[mm]	426
Width	[mm]	65
Height*	[mm]	205
Weight	[kg]	3.27

\* Without magazine, flip-up sights folded.



### 2.3.3 Technical data - SPC40 G HA

Designation	SPC40 G HA
Product ID	BT-500001-40
Caliber	.40 S&W
Magazine capacity	22 round
Rifling	6 Grooves, Right hand twist

Barrel Length	[mm]	230
Length Standard	[mm]	625
Length Receiver	[mm]	411
Width	[mm]	65
Height*	[mm]	205
Weight	[kg]	3.09

\* Without magazine, flip-up sights folded.

### 2.3.4 Technical data - SPC45 HA

Designation	SPC45 HA
Product ID	BT-500001-45
Caliber	.45 ACP
Magazine capacity	15/30 round
Rifling	6 Grooves, Right- or left hand twist

Barrel Length	[mm]	230
Length Standard	[mm]	625
Length Receiver	[mm]	411
Width	[mm]	65
Height*	[mm]	205
Weight	[kg]	2.95

\* Without magazine, flip-up sights folded.

2.4 Variant overview

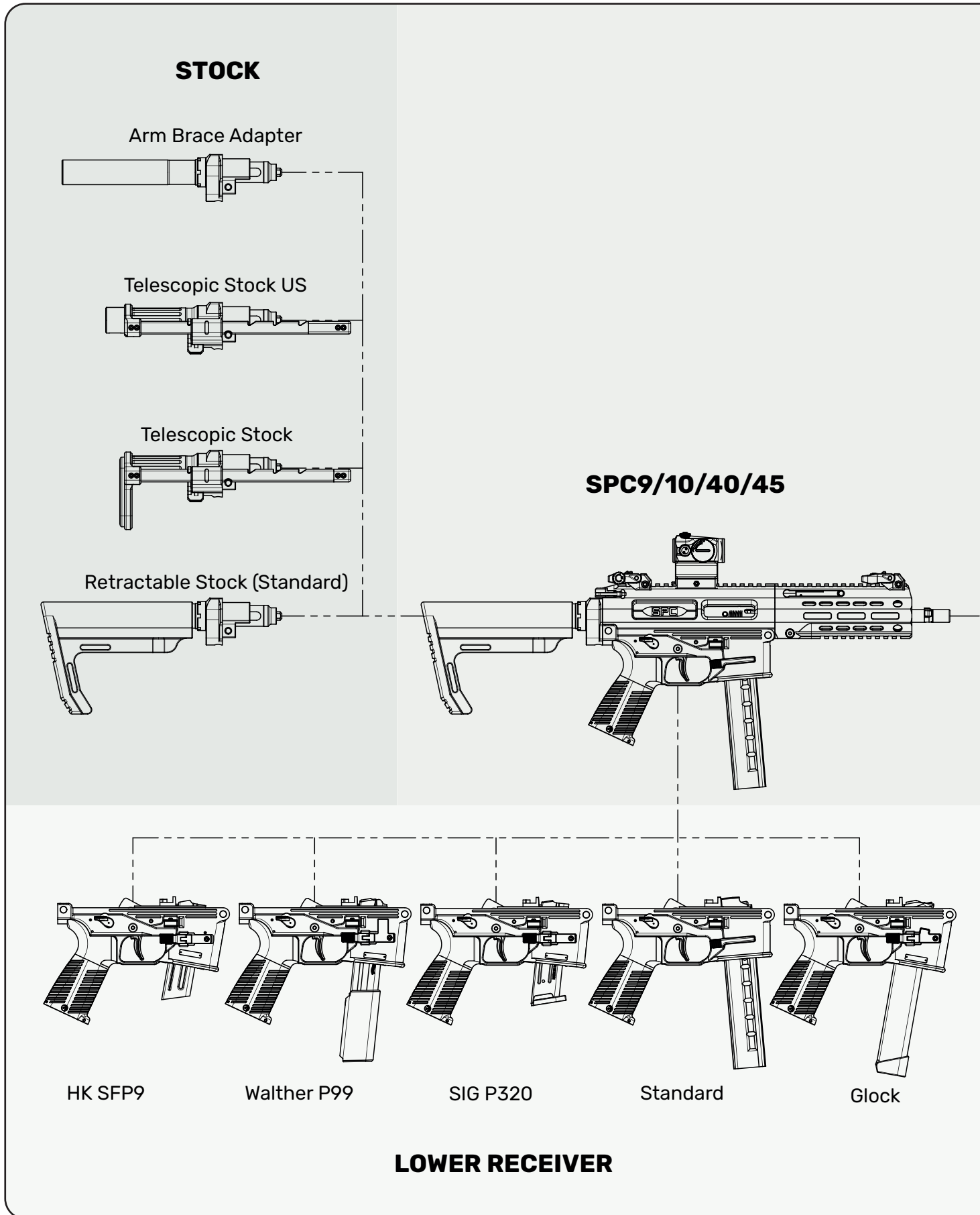

### UPPER RECEIVER

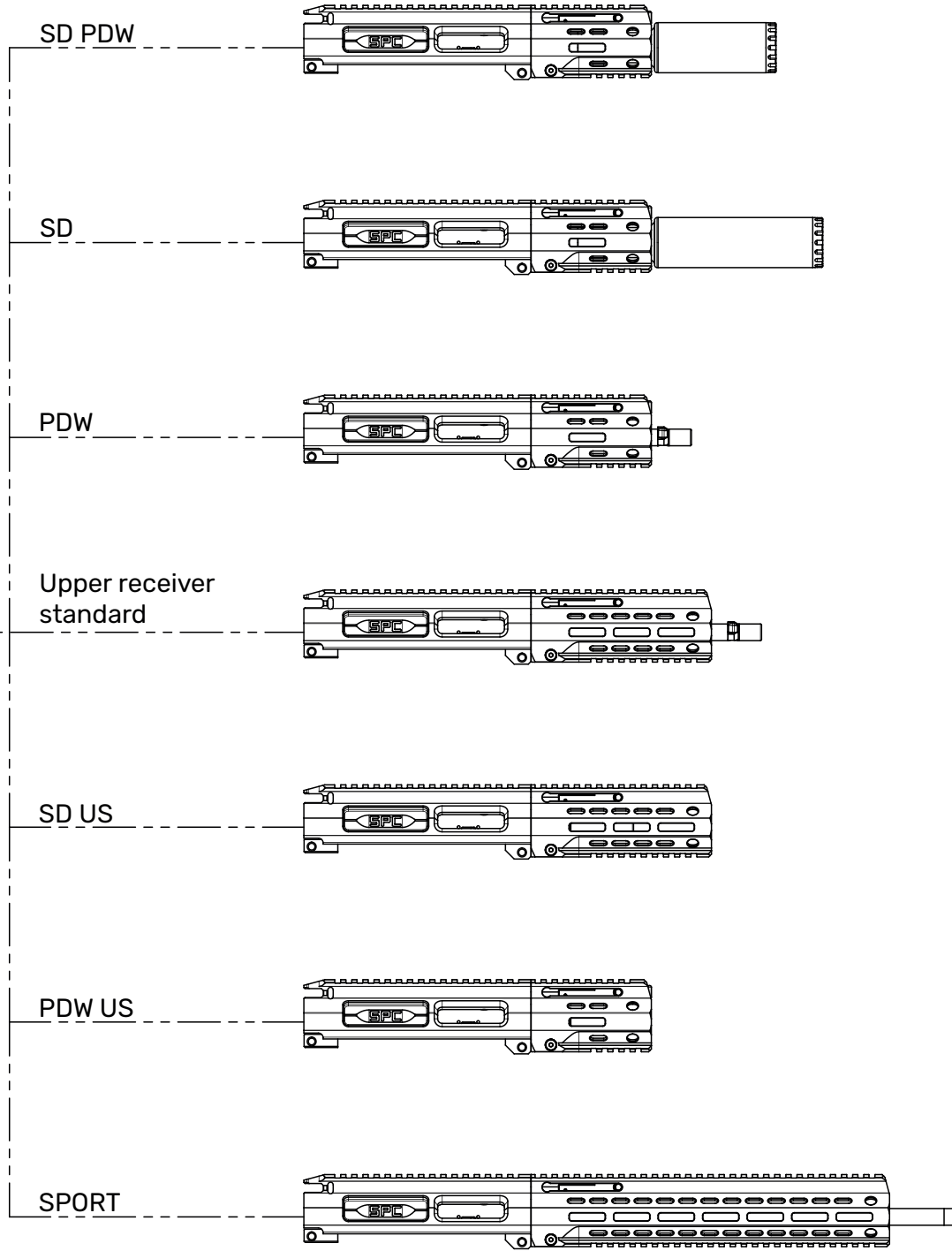

### 3. Nomenclature

#### 3.1 Weapon complete

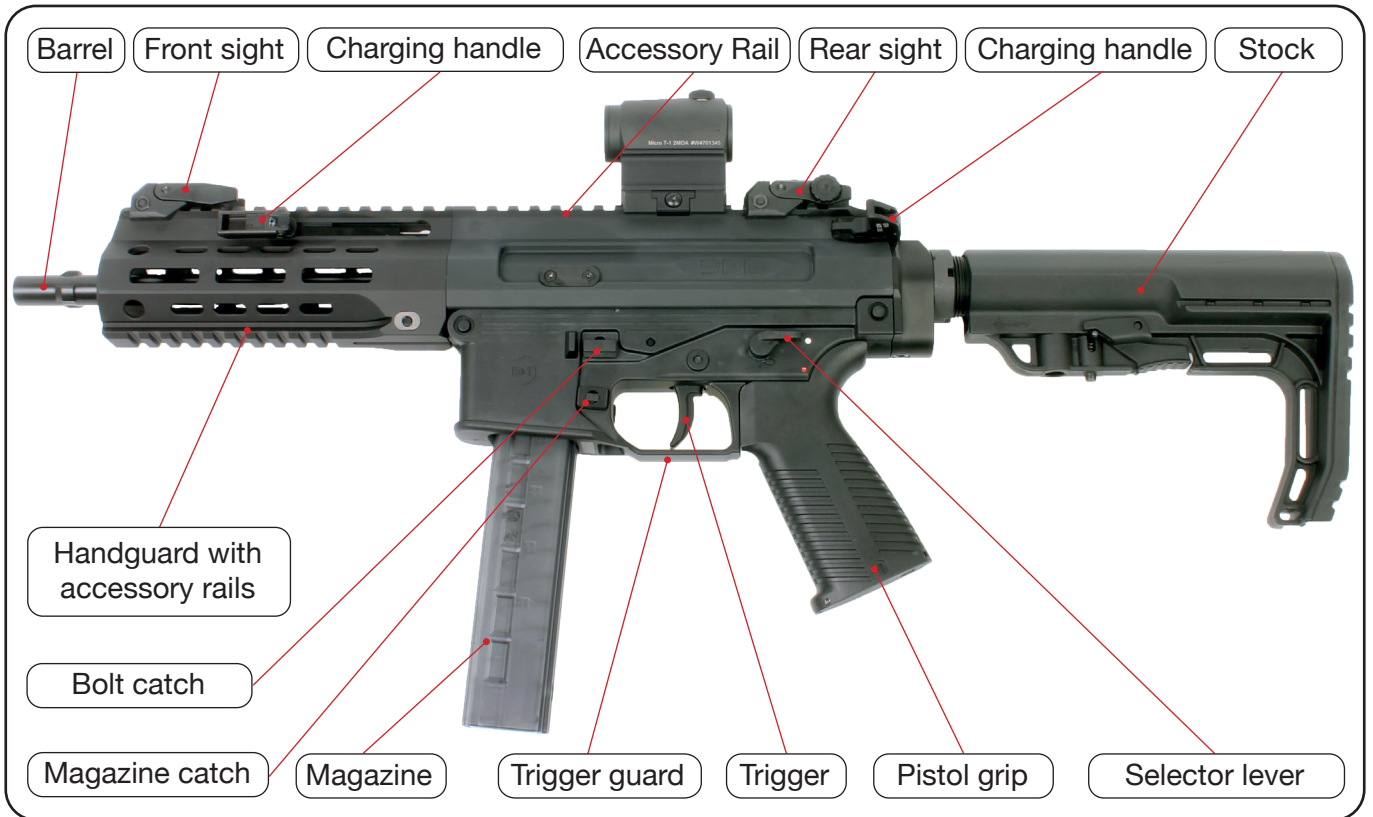

#### 3.2 Weapon disassembled

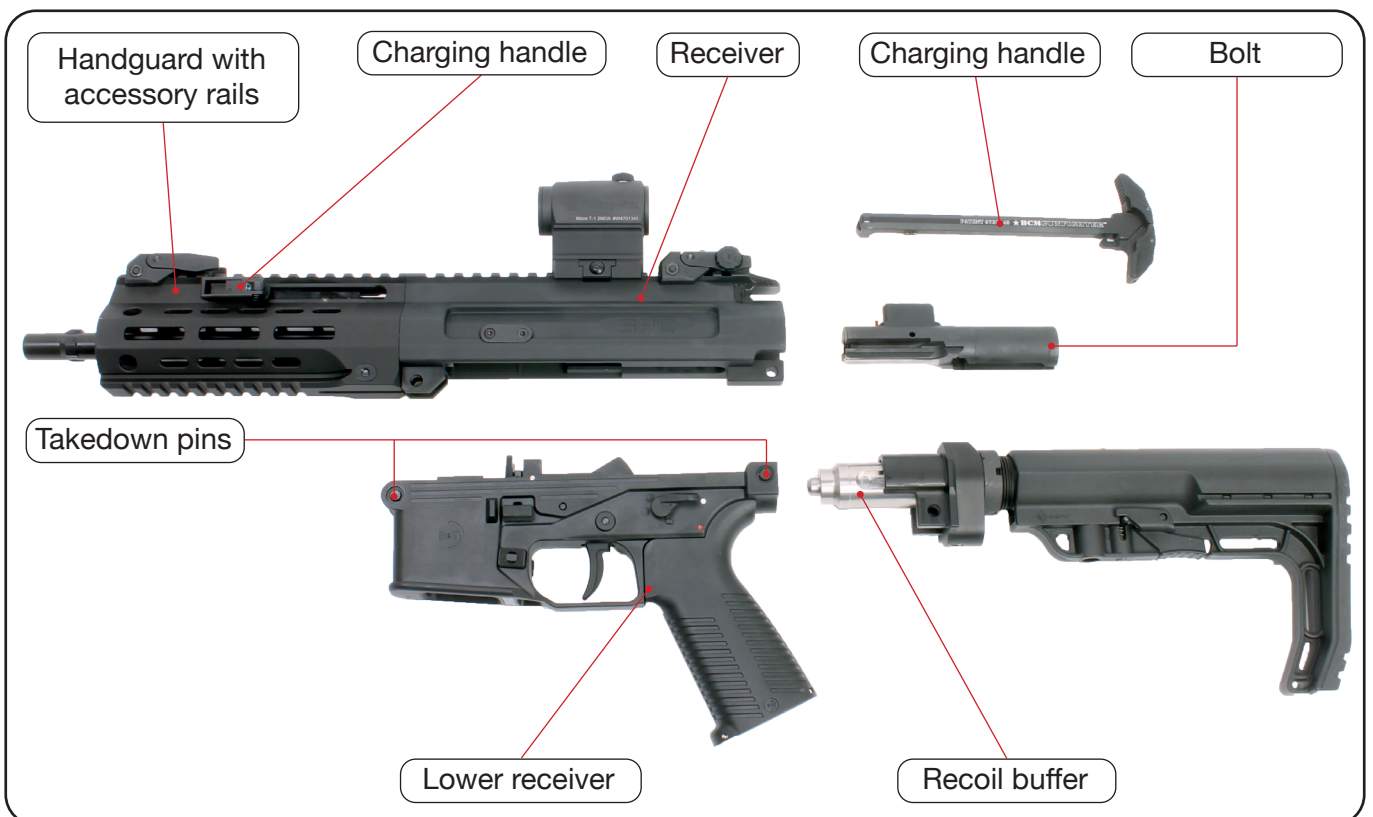

## 4. Handling and operating procedures

### 4.1 Clearing weapon

- Rotate the fire selector to “safe” position (see chapter „4.2 Operating fire selector“ on page 13).
- Press the magazine retainer and pull the magazine downward out.

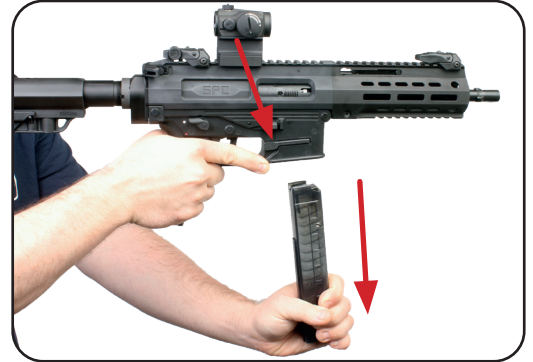

- Pull the charging handle completely to the rear and inspect the chamber visually to be clear.
- Lock the bolt in open position (see chapter „4.8 Bolt catch“ on page 21).



### 4.2 Operating fire selector

- The positions of the fire selector are marked on both side of the weapon.
- Rotate the fire selector in order to engage the desired mode.



WHITE DOT = SAFE

RED DOT= SINGLE FIRE

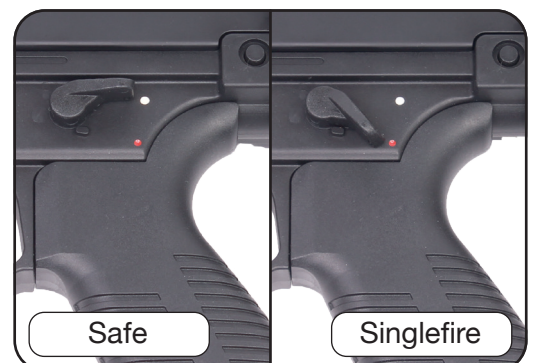

## 4.3 Magazine catch

### 4.3.1 Operating magazine catch

- Rotate the fire selector to “safe” position (see chapter „4.2 Operating fire selector“ on page 13).
- Press the magazine retainer and pull the magazine downward out.



### 4.3.2 Magazine catch standard magazine

- Magazine catch of the standard magazine on left and right side of the lower receiver.

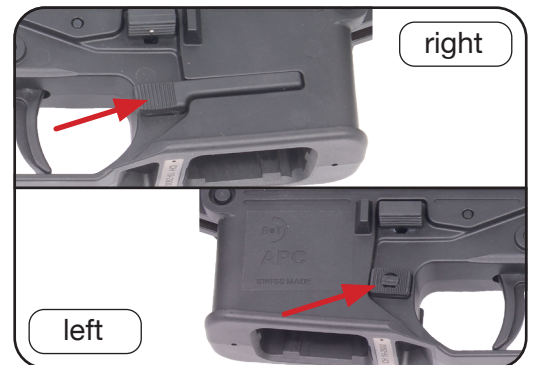

### 4.3.3 Magazine catch Glock magazine

- Magazine catch of the Glock magazine on left and right side of the lower receiver.

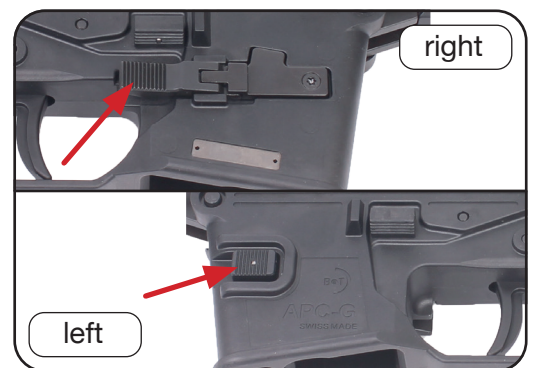

### 4.3.4 Magazine catch SIG magazine

- Magazine catch of the SIG magazine on left and right side of the lower receiver.

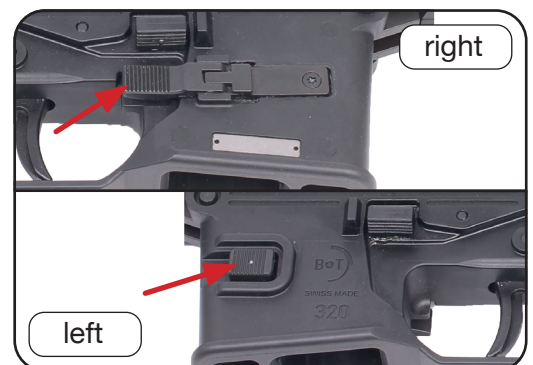

## 4.4 Stock / Adapter

### 4.4.1 Retracting sliding stock

- Grasp the weapon with the firing hand on the pistol grip.
- Push the Locking knob with the non firing hand, and push in the stock.

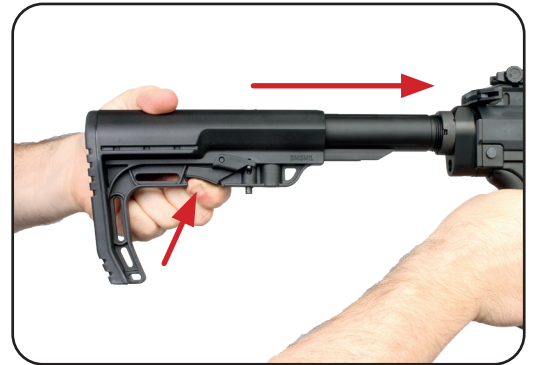

- Push in the Stock until it reaches the end position and locks audibly.

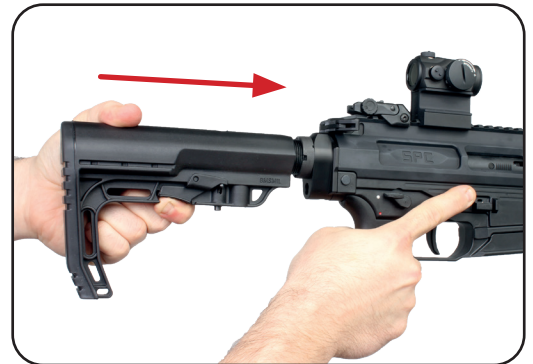

### 4.4.2 Extracting sliding stock

- Grasp the weapon with the firing hand on the pistol grip.
- Push the locking knob with the non firing hand, and pull out the stock.
- Pull out the stock until it reaches the desired position.

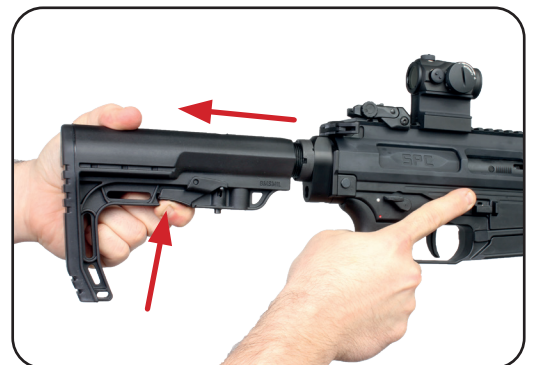

Then release the locking knob and lock the stock on one of the various locking positions.

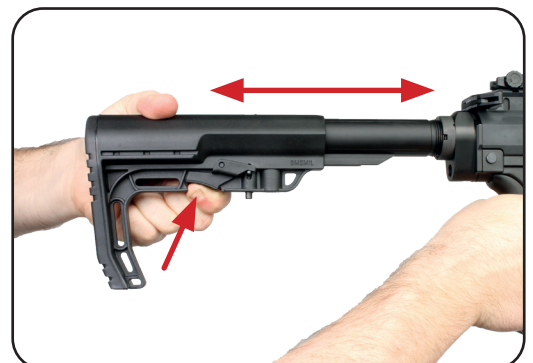

#### 4.4.3 Retracting telescopic stock

- a. Grasp the weapon with the firing hand on the pistol grip.
- b. Push the Locking knob with the thumb of the firing hand, and push in the stock.

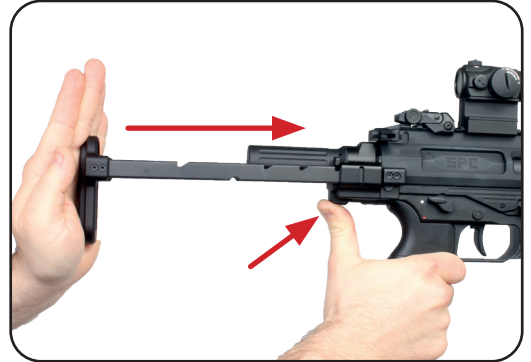

- c. Push in the Stock until it reaches the end position and locks audibly.



#### 4.4.4 Extracting telescopic stock

- a. Grasp the weapon with the firing hand on the pistol grip.
- b. Push the locking knob with the non firing hand, and pull out the stock.



- c. Pull out the stock until it reaches the desired position. Then release the locking knob and lock the stock on one of the various locking positions.

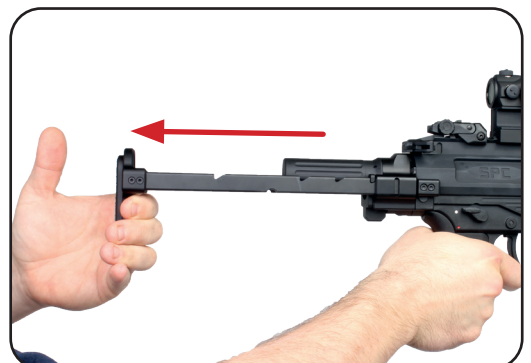



## 4.5 Pistol grip storage compartment

### 4.5.1 Open the pistolgripcover

- a. Slide a screw driver in the gap at the front of the compartment cover.
- b. Push the cover backward and lift it up.



### 4.5.2 Close the pistolgripcover

- c. In order to close the cover, push it back until it audibly snaps into closed position.



## 4.6 Iron sights

### 4.6.1 Engaging iron sights

a. Push front sight up until it snaps in upright position

b. Push rear sight up until it snaps in upright position

c. Select large or small aperture.

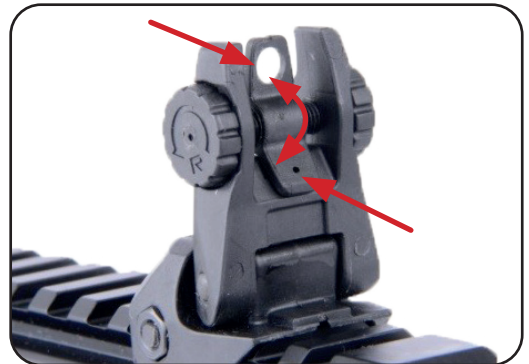
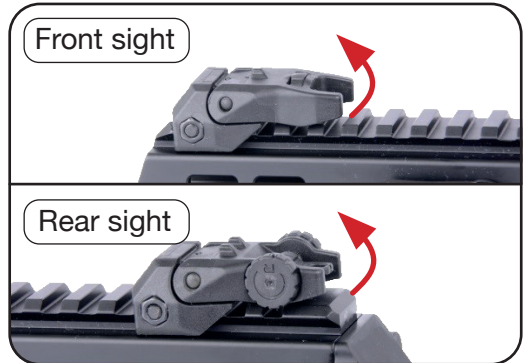

### 4.6.2 Adjustments

a. Turn the adjusting wheel in the front sight in the direction of the arrow «UP» to raise the MPI.



b. Turn the rear sight wheel in the direction of the arrow «R» to move the MPI to the right.

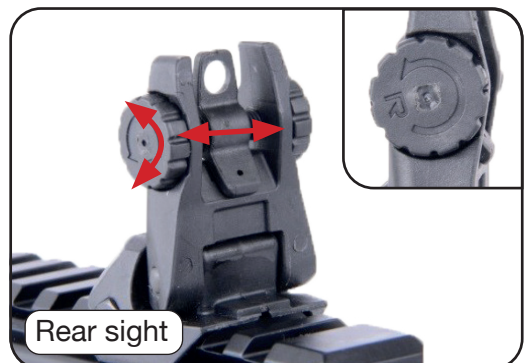

## 4.7 Disassembly & Assembly Charging Handle

### 4.7.1 Disassembly Charging Handle

On the SPC, it is possible to permanently remove the front charging handle and the associated charging slide.

To prevent dirt from entering the receiver, a slide cover can be mounted.

a. Disassemble the weapon completely as shown in «chapter „5.1.1 Disassembly of the weapon“ on page 24».

b. Insert the slider cover into the receiver and push it in until it is aligned with the housing.

c. Mount the slide cover with the screw included in the delivery.

d. Reassembly the weapon as shown in «chapter „5.3.1 Reassembly of the weapon“ on page 27».

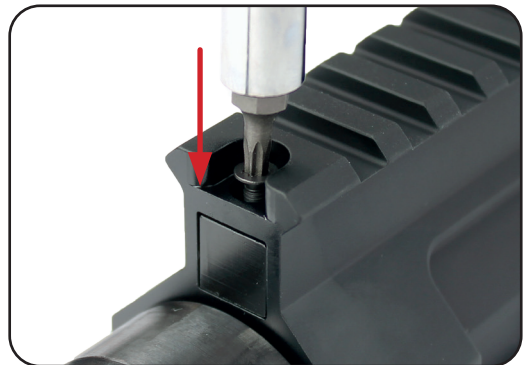
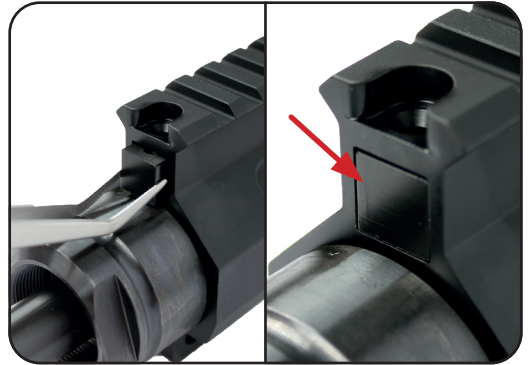

#### ADVICE!



When assembling the weapon, skip the steps for assembling the charging lever and the charging handle.

#### 4.7.2 Assembly Charging handle

a. Disassemble the weapon completely as shown in «chapter „5.1.1 Disassembly of the weapon“ on page 24».



b. Loosen and remove the screw of the slide cover.

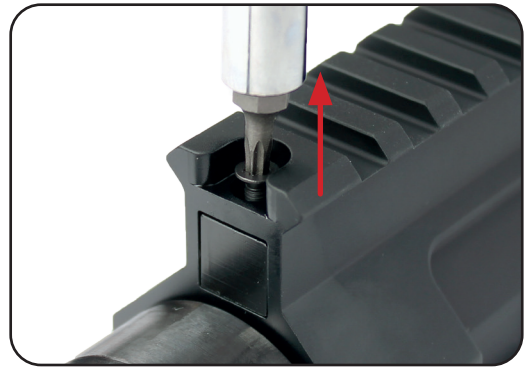

c. Hold the housing at a slight angle and remove the slide cover.

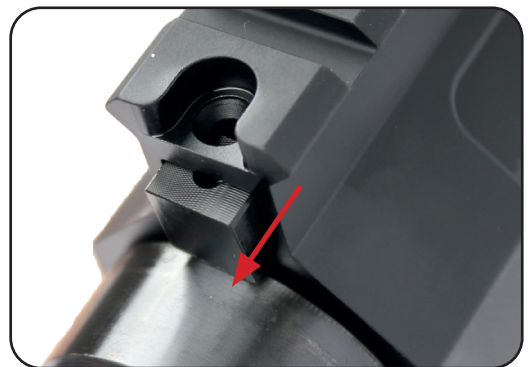

d. Reassembly the weapon as shown in «chapter „5.3.1 Reassembly of the weapon“ on page 27».



## 4.8 Bolt catch

### 4.8.1 Holding bolt in open position

- Remove magazine (see chapter „4.3 Magazine catch“ on page 14).
- Grab the charging handle and pull the bolt to the rear-most position and hold it there.

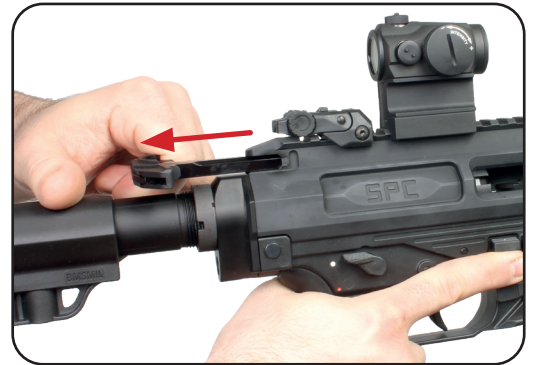

- Push the bolt catch upwards (available on left and right weapon side).
- Allow the bolt to travel forward until stopped and held by the bolt catch.
- Push the charging handle to its foremost position.



### 4.8.2 Closing Bolt

- Push the external bolt catch (available on left and right weapons side) until the bolt snaps into closed position.



## 4.9 Loading and unloading weapon

### 4.9.1 Loading weapon

- Fill the cartridges one by one into the magazine.
- Grab the weapon and engage safety (see chapter „4.2 Operating fire selector“ on page 13).
- Insert magazine.
- Pull the magazine slightly downward to verify it is locked in place.



- If the bolt is open, push the external bolt catch downwards.



- If the bolt is closed, vigorously pull back the charging handle to its rearmost position and allow the bolt to snap forward under its own power.
- Slightly pull the bolt rearward until you can spot the brass of the chambered cartridge in order to verify the weapon is loaded.



### 4.9.2 Unloading weapon during firing sessions

- Engage safety (see chapter „4.2 Operating fire selector“ on page 13).
- Remove the magazine (see chapter „4.3 Magazine catch“ on page 14).
- Pull the charging handle rearward and observe the chambered cartridge being ejected.
- Hold the bolt in open position using the bolt catch (see chapter „4.8.1 Holding bolt in open position“ on page 21) and make a visual check to see if the chamber is empty.
- Recover the loose cartridge.

### 4.9.3 Unloading weapon for storage

- Unload the weapon (see chapter „4.9.2 Unloading weapon during firing sessions“ on page 22).
- Close the bolt (see chapter „4.8.2 Closing Bolt“ on page 21).
- Disengage safety (see chapter „4.2 Operating fire selector“ on page 13).
- Point the weapon into a safe direction and pull the trigger – the hammer strikes audibly.
- Engage safety (see chapter „4.2 Operating fire selector“ on page 13).
- Lock the Bolt to the rear (see chapter „4.8.1 Holding bolt in open position“ on page 21).
- Insert the “Safety-Flag”.
- Close the bolt with the safety flag inserted (see chapter „4.8.2 Closing Bolt“ on page 21).

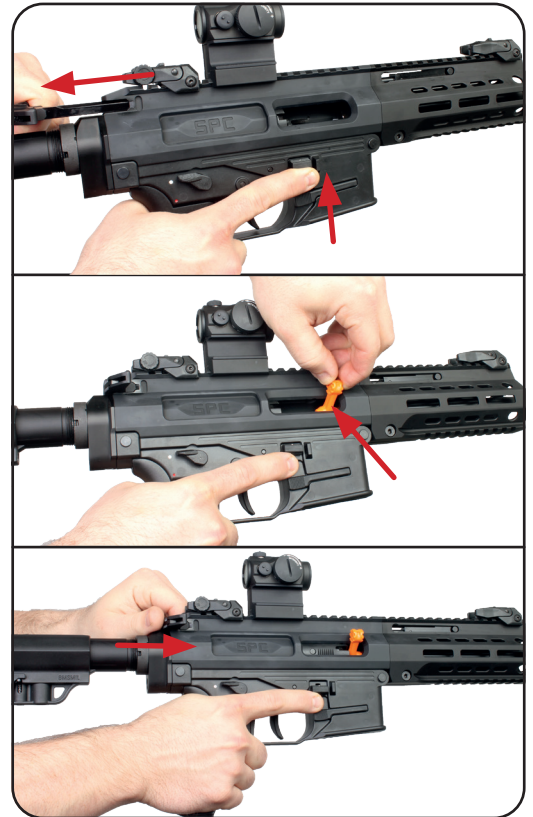

### 4.10 Firing the SPC9

#### SAFETY ADVICE!



REFER TO CHAPTER „1.1 SAFETY RULES“ ON  
PAGE 5

- Engage iron sights (see chapter „4.6.1 Engaging iron sights“ on page 18).
- Load the Weapon (see chapter „4.9.1 Loading weapon“ on page 22).
- Apply a proper firing position.
- Aim on target.
- Disengage Safets (see chapter „4.2 Operating fire selector“ on page 13) .
- Pull the trigger until the shot is released.



#### Advice



Refer to chapter „5.4 Functional check“ on page 31 in case of malfunctions.

## 5. Maintenance procedures

### Advice!



DO NOT OPERATE THE TRIGGER WHEN THE WEAPON IS DISASSEMBLED.



## 5.1 Disassembly

### 5.1.1 Disassembly of the weapon

- Clear the weapon (see chapter „4.1 Clearing weapon“ on page 13).
- Close the bolt (see chapter „4.8 Bolt catch“ on page 21).
- Press the front and rear take-down pin from left side to right side and pull it out from right side until the lower receiver comes loose.



### Advice



The telescopic stock must be in retracted position for pushing out the rear take-down pin.

- Grasp Stock and slide it out of the upper receiver.

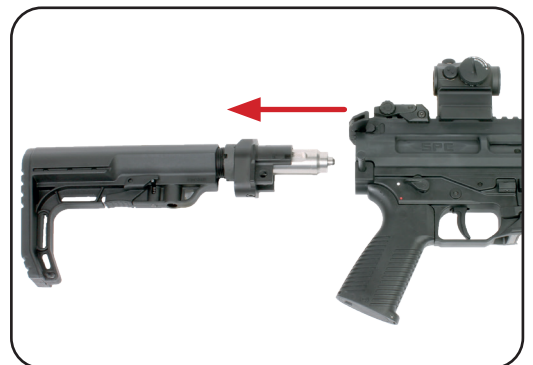

- Separate the lower receiver from the weapon.

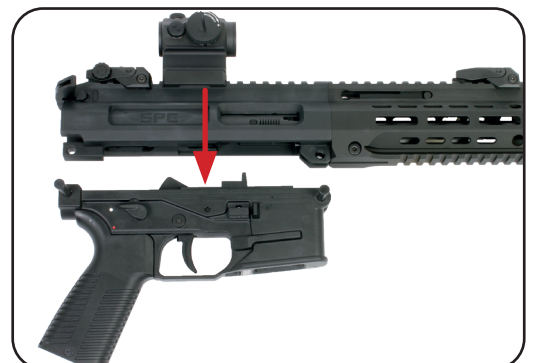



f. Operate the locking mechanism on the charging handle and move it slightly rearward.

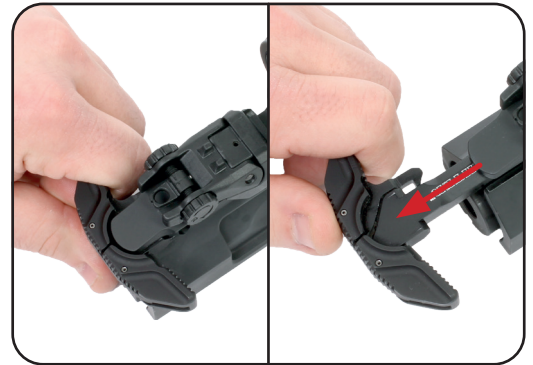

g. Move the charging handle further rearwards until you can see the bolt.



h. Pull the bolt rearward out of the receiver and remove it.



i. Move the charging handle further rearwards until you reach the position where you can pull it downwards.

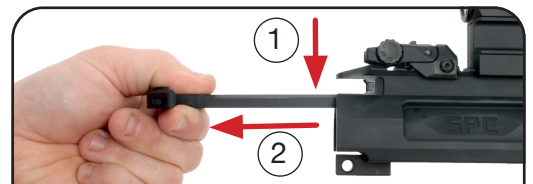

j. Remove the charging handle from the upper receiver.

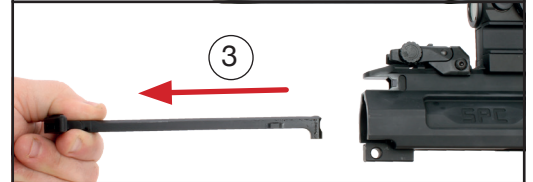

The weapon is now disassembled and ready for cleaning and inspections.



### 5.1.2 Disassembly of the upper receiver

- a. Loosen the securing bolt, and remove it together with its nut.
- b. Pull the handguard forwards from the Receiver.
- c. Pull the front charging handle back until it is congruent with the cutout in the receiver.
- d. Pull out the front charging handle sideways and remove it from the handguard.
- e. Remove the charging handle carrier rearwards out of the handguard.

The upper receiver is now disassembled and ready for cleaning and inspections.

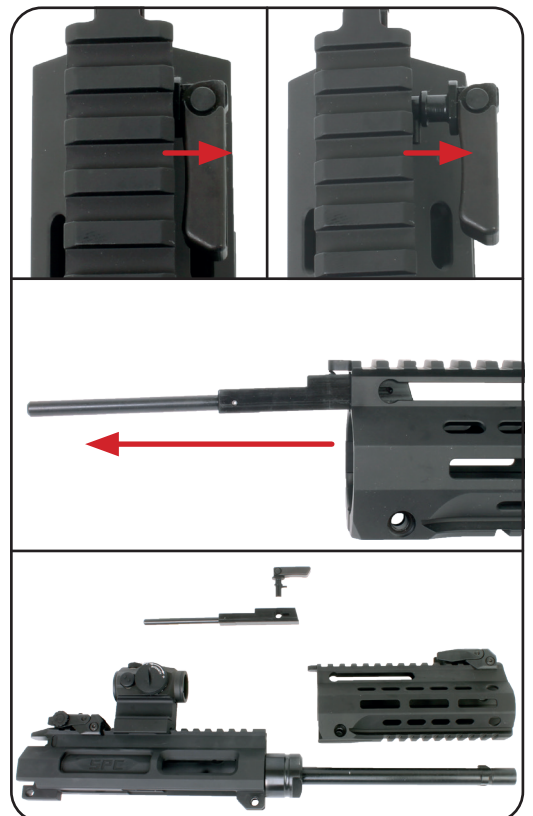
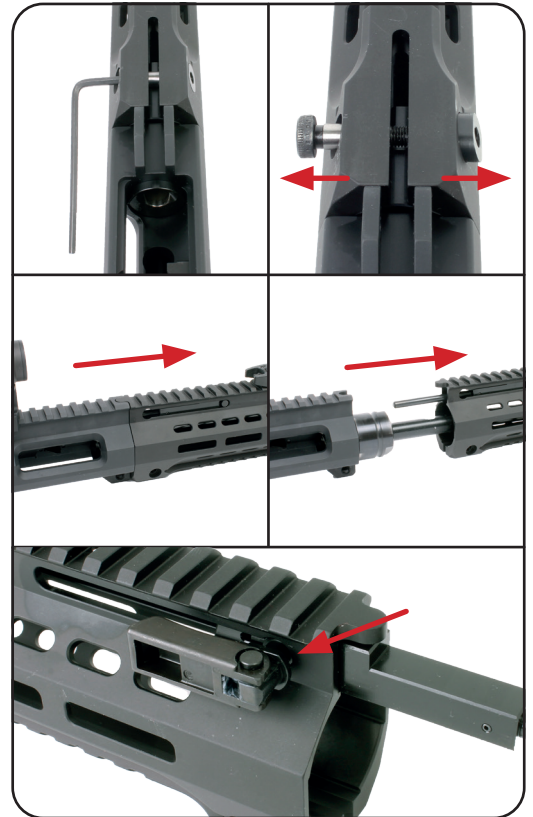

## 5.2 Cleaning and inspections

- Use a cleaning rod of suitable length with a copper brush to clean the barrel from the rear side.
- Use a small brush to remove particles captured in the cavities of lower and upper receiver.
- Use an oiled rag to wipe clean all accessible surfaces.
- Inspect all components and accessible parts for cracks, deformations or other signs of deterioration.
- Apply a slight film of oil to all accessible surfaces of steel parts.

### SAFETY ADVICE!



ADDRESS TO AN ARMORER IF THE SERVICEABILITY OF THE WEAPON SEEMS DOUBTFUL.

## 5.3 Reassembly

### 5.3.1 Reassembly of the weapon

- Assemble the upper receiver (see chapter „5.3.2 Assembly of the upper Receiver“ on page 29)
- Insert the charging handle into the Receiver.
- Until it reaches the correct position to push it up into its track in the receiver.
- Push the charging handle up and insert it 1-2cm more into the receiver.

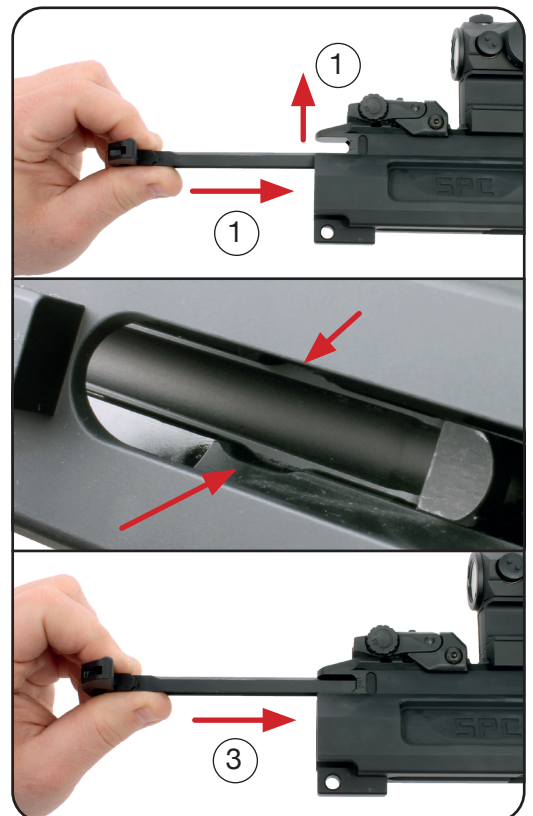

- e. Insert the Bolt into the Receiver.
- f. The Guidance for the Bolt must be congruent with the guiding recess in the charging handle.
- g. Push in the charging handle until it locks into the receiver.
- h. Grasp the Stock and insert it into the Receiver.

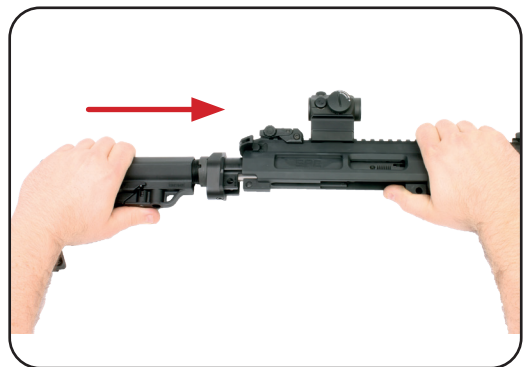
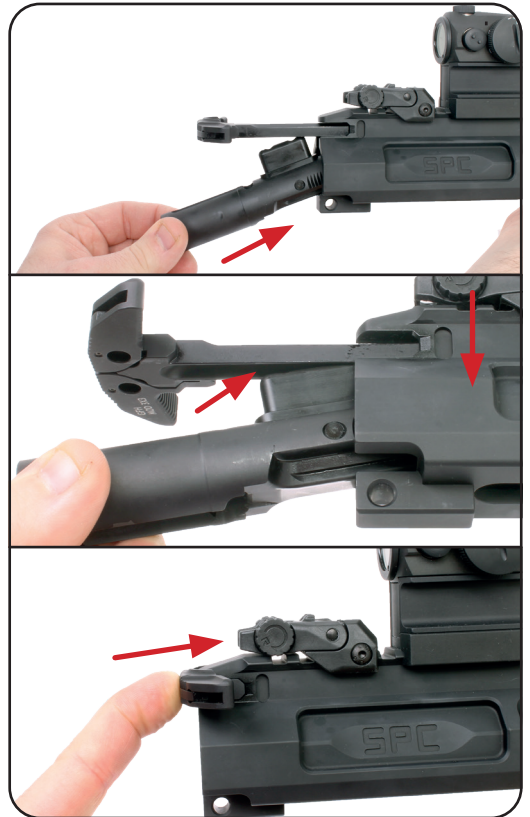

<b>Advice!</b>	
	The telescopic stock must be in retracted position for pushing in the rear take-down pin.

- i. Place the lower receiver on the receiver and push in the front and rear take-down pin from the right side.
- j. Execute a functional check (see chapter „5.4 Functional check“ on page 31).



### 5.3.2 Assembly of the upper Receiver

- a. Insert the charging handle carrier from the back into the handguard.

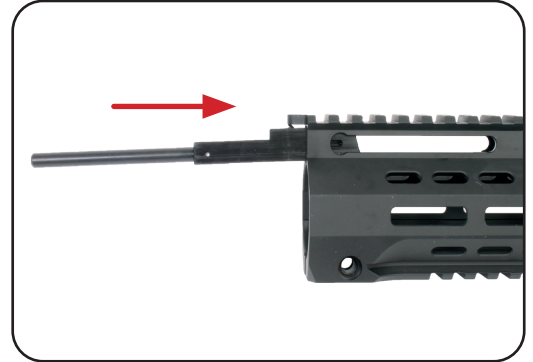

- b. Push in the charging handle carrier until it is congruent with the cutout for installing the front charging handle.

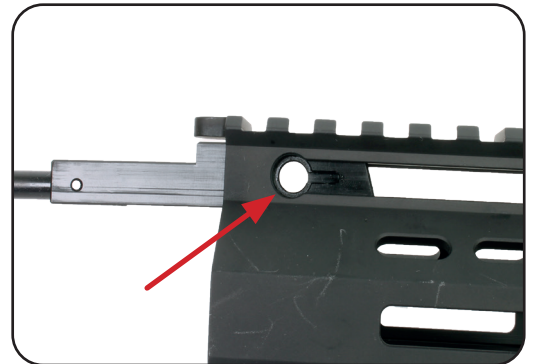

- c. Make sure to insert the front charging handle in the correct orientation in order for the pin to slide into the recess in the charging handle carrier.

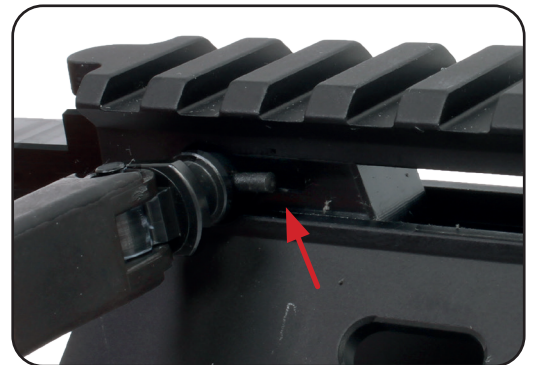

- d. Push in the front charging handle all the way.  
e. The front charging handle can be inserted on both sides of the handguard, depending on the users desire.

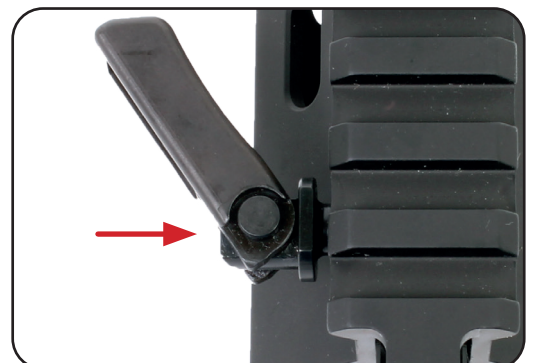

- f. Slide the front charging handle forwards until it reaches the position in order for the ball to lock in the recess in the Handguard.

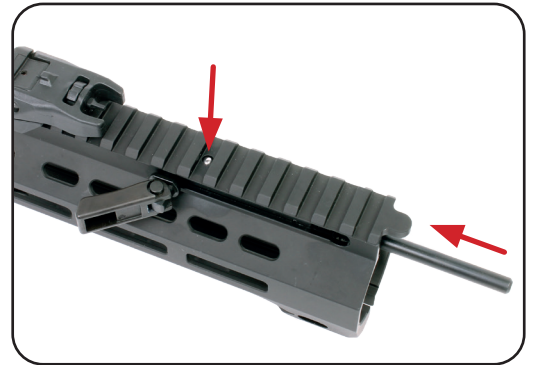

- g. Slide the handguard all the way onto the upper receiver.

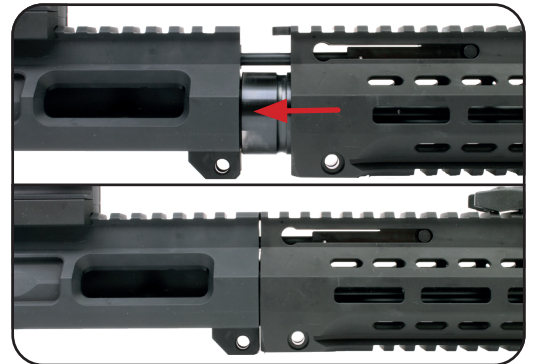

- h. Insert the nut of the securing bolt into the recess in the handguard. Pay attention to the correct orientation.



- i. Mount the securing bolt.

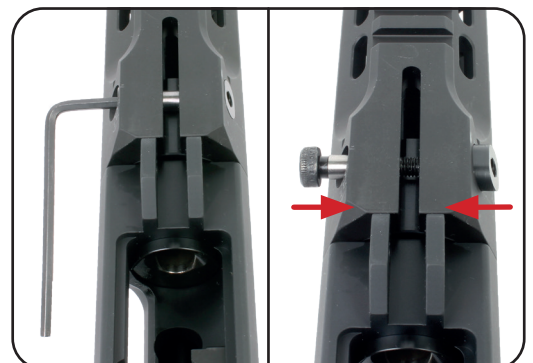

## 5.4 Functional check

- a. Clear weapon (see chapter „4.1 Clearing weapon“ on page 13).
- b. Push on right side bolt catch » bolt shall snap into closed position.
- c. Pull charging handle to its rearmost position and push bolt catch upward » bolt shall stay in open position.
- d. Push on left side bolt catch » bolt shall snap into closed position.
- e. Engage safety and pull trigger » hammer shall not strike.
- f. Rotate right side fire selector to single fire position and back to safe position » shall snap audibly in both positions.
- g. Rotate left side fire selector to single fire position, pull trigger and hold » hammer shall strike audibly.
- h. Pull charging handle to the rearmost position and slide it to forward position. Release trigger and pull it again » hammer shall strike audibly
- i. Engage safety, insert an empty magazine and pull downward » magazine retainer must hold securely.
- j. Pull charging handle to rearmost position and release => bolt shall stay open.
- k. Push left magazine retainer and pull magazine downward => magazine shall come loose.
- l. Reinsert empty magazine, push right magazine retainer and pull magazine downward => magazine shall come loose.
- m. Pull charging handle to the rearmost position and release => Bolt shall run to closed position. Repeat steps i to m with all available magazines.
- n. Engage sights => both shall audibly snap in open position and point straight upward.
- o. Close sights => both shall audibly snap in closed position.
- p. Check extracting and retracting and locking mechanisms of installed Stock for proper function (see chapter „4.4 Stock / Adapter“ on page 15)
- q. Inspect installed accessories for function and tight mounting.

If any function fails, disassemble the weapon, check for defective parts, reassemble the weapon and check for correct reassembly. If the failure persists, refer to armorer.

## 5.5 Troubleshooting table

#	Observation	Immediate action	Ref.
1	Inconsistent impacts	Control correct position and tight sit of the iron sights. Present weapon at first opportunity to armourer for inspection.	4.6
2	Failure to feed	Pull charging handle to rearmost position and release. Inspect visually if a cartridge is chambered. In case of jam, remove magazine, clear and switch to other magazine.	4.9
3	Failure to eject	Pull charging handle to rearmost position and observe for ejected shell or cartridge. Inspect barrel to be clear. Load a fresh cartridge. Present weapon for inspection of extractor and ejector to an armourer at the first opportunity.	4.9
4	Failure to strike	Pull charging handle to rearmost position and remove eventual obstructions captured in the upper receiver. Load a fresh cartridge. If failure repeats, clean weapon or present it to an armorer.	4.9 5
5	Failure to ignite	Wait 30 seconds with the muzzle pointing to a safe direction. Then pull charging handle to rearmost position and observe for ejected cartridge. Collect cartridge for later analyses. Load a fresh cartridge. Present weapon and ejected cartridge to an armorer at the first opportunity.	4.9

### Advice!







Failure reports to the manufacturer must include the serial number of the weapon, the type of ammunitions, the history of the failure and the history of the attempted corrective actions. The report can be sent to B&T by E-Mail along with pictures



## 6. Accessories

### 6.1 Stocks / Adapters

Picture	Art.-No.	Description
	BT-500038	Sliding stock (Standard)
	BT-200616	Telescopic Arm Brace Adapter
	BT-200614	Telescopic Stock (for PDW)
	BT-500047	Pistol Adapter

## 6.2 Magazines

Picture	Art.-No.	Description
	BT-30183	Magazine 30 rounds
	BT-30298	Magazine 25 rounds
	BT-30296	Magazine 20 rounds
	BT-30209	Magazine 15 rounds
	BT-231229	Magazine loader

Picture	Art.-No.	Description
 A black plastic magazine clamp with a textured surface and a circular hole on the side.	BT-22379	Magazine clamp

### 6.3 Flashhider

Picture	Art.-No.	Description
 A black plastic flashhider with a textured grip and a circular opening at the end.	BT-400983	Flashhider Vortex QD



## 6.4 Silencer

Picture	Art.-No.	Description
 <p>A black cylindrical silencer with a mounting bracket on the right side. The left end has a multi-hole muzzle. Text on the side includes: B&amp;T logo, 17-50820, 9 mm, SQD, SD-988206, Rev. 00, and B&amp;T AG Instrument.</p>	SD-988206	Silencer SQD™
 <p>A black cylindrical silencer with a multi-hole muzzle on the left end and a threaded cap on the right end.</p>	SD-988100	Silencer QD™
 <p>A black cylindrical silencer with a multi-hole muzzle on the left end and a textured, knurled cap on the right end.</p>	SD-988100-C	Silencer compact QD™
 <p>A large grey information icon consisting of a lowercase 'i' inside a circle.</p>	SD-123020	Silencer RBS-9 QD
 <p>A large grey information icon consisting of a lowercase 'i' inside a circle.</p>	SD-123020	Silencer RBS-9 QD

## 6.5 Lights

Picture	Art.-No.	Description
	BT-WML-B-W-L-GEN2	WML GEN-2 Weapon mounted light

## 6.6 Sights

Picture	Art.-No.	Description
	AP-Micro-T-1	Aimpoint® Micro T-1
	AP-200504	Aimpoint® ACRO P-1 black

## 6.7 Grips

Picture	Art.-No.	Description
	BT-231227-BK	Angled fore grip 45° picatinny rail attachment
	BT-211564-BL	Unigrip QD short
	BT-21840	Unigrip QD



## 6.8 Slide cover

Picture	Art.-No.	Description
	BT-500028	Slide cover

## 6.9 Brasscatcher

Picture	Art.-No.	Description
	BT-220581	Brasscatcher

## 6.10 Maintenance

Picture	Art.-No.	Description
	SC-99B/6	Cleaning rod extension
	SC-65B	Copper brush 9 mm

## 7. Warranty statement

Warranty claims on behalf of the Client are to be explicitly declared as such. During the legal warranty period, B&T provides warranty cover solely for defects that arise as a result of faulty materials, construction errors or poor workmanship. If a warranty claim is justified, B&T will, at its own discretion, either repair or replace the defective good. Costs incurred in transporting the defective good to B&T are borne by the Client. Spare parts fitted and replaced become the property of B&T.

Inasmuch as is legally permitted, any other liability of B&T is excluded, in particular liability for damages arising either directly or indirectly from the delivered good itself, from its use or from its defects

Merchandise is covered by the warranty provisions of the manufacturer. Parts that are naturally subject to wear and tear, damage arising from insufficient maintenance work, noncompliance with operating regulations and cases of force majeure are all excluded from warranty cover. Warranty claims lapse if the Client itself or third parties alter or repair the delivered good without the prior written consent of B&T. All product specifications are subject to change without prior notice. Published data are mean values and therefore not suitable acceptance criteria.

The manufacturer:

B&T AG - 3608 Thun - Switzerland

Phone +41 33 334 67 00

e-mail: [info@bt-ag.com](mailto:info@bt-ag.com)

Notes: