

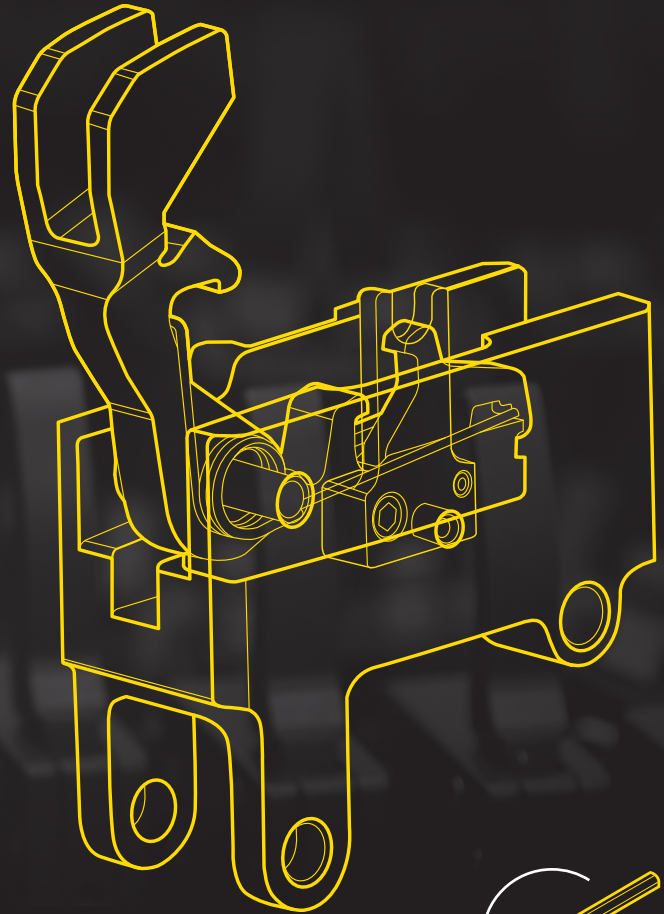

# TAVOR SEAR PACK INSTALLATION INSTRUCTIONS

Thank you for purchasing this Timney Trigger. It has been designed and manufactured to provide you with a lifetime of dependable service. Each trigger is hand tested and calibrated on an action specific to your platform before leaving our factory. Please read these instructions fully before you begin installing the trigger, you'll be glad you did.



## TOOLS NEEDED:



Straight Punch

## TIMNEY TRIGGER GUARANTEE

**Material and workmanship:** This Timney trigger has been carefully inspected, tested and adjusted to give a lifetime of dependable service. Every possible care has been exercised in its design and construction. If any defect in workmanship or material should develop under conditions of normal use and service, any necessary repairs, including parts and labor will be made at NO CHARGE to the purchaser providing that our inspection reveals parts were not damaged through accident, alteration, misuse, abuse or other causes beyond our control. We neither assume nor imply any oral or statutory warranties, and we neither assume nor authorize any person to assume for us any obligation or liability in connection with this trigger. Repairs or disassembly of this trigger in any manner without specific authorization, voids the guarantee.

**IF YOU HAVE TROUBLE CHECK OUT TROUBLESHOOTING STEPS ON  
[WWW.TIMNEYTRIGGERS.COM](http://WWW.TIMNEYTRIGGERS.COM) OR CONTACT US**

Timney can also install your trigger for \$40.00 plus \$35.00 shipping and handling.

Mail: 2020 W Quail Ave, Phoenix AZ. 85027 Phone: 623-223-1111 Fax: 623-223-1112 Support: [technicalsupport@timneyusa.com](mailto:technicalsupport@timneyusa.com)

# INSTALLATION INSTRUCTIONS

**PLEASE NOTE:** BE SURE THE HAMMER IS IN THE COCKED POSITION BEFORE ATTEMPTING TO REMOVE THE SEAR HOUSING MECHANISM

- 1** Unload the rifle and remove the magazine, visually and physically ensure that the rifle is **unloaded** before beginning trigger installation
- 2** Press the two locking pins on the **right** side and pull them through the rifle to the **left** side of the rifle until they stop.
- 3** Pull the sear pack out of the housing
- 4** With the stock sear pack removed place the TIMNEY sear pack into the housing and reinsert the locking pins into the housing
- 5** Close the bolt carrier stop lever and dry fire the weapon unloaded to make sure everything is working properly
- 7** Now go out and enjoy your new Timney Trigger!

Please note the pins have detents to prevent them from being pulled out completely

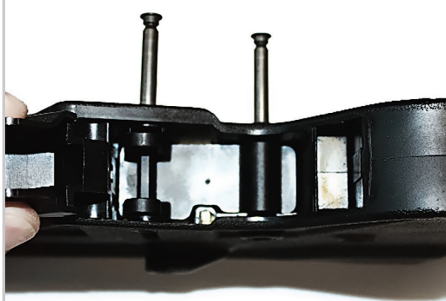

Pins out with open Bolt carrier lever



Hammer Released Position



Hammer Cocked Position

## FUNCTION AND SAFETY CHECK

DO ALL FUNCTION TESTING WITH AN UNLOADED RIFLE

- 1 FUNCTIONAL TESTING**
  - Verify the sear pack is inserted correctly and the bolt carrier is closed and the retaining pins inserted
  - Verify the selector switch moves from fire to safe freely
- 2 SAFETY TESTING**
  - Verify the safety is working properly when the selector switch is set on safe.
    - With the safety engaged and the trigger is pulled does the hammer release?
    - When the safety is released does the hammer release?
- 3 PULL WEIGHT**
  - The pull weight is preset from the factory at 3.5-4 lbs. This can't be adjusted on the sear pack.



Downloadable Instructions

**IF YOU HAVE TROUBLE CHECK OUT TROUBLESHOOTING STEPS ON [WWW.TIMNEYTRIGGERS.COM](http://WWW.TIMNEYTRIGGERS.COM) OR CONTACT US**

Timney can also install your trigger for \$40.00 plus \$35.00 shipping and handling. **Mail:** 2020 W Quail Ave, Phoenix AZ. 85027  
**Phone:** 623-223-1111 **Fax:** 623-223-1112 **Support:** [technicalsupport@timneyusa.com](mailto:technicalsupport@timneyusa.com)

